

Cairo Large LED 3000K

Cairo Large LED, a slightly bigger version of our Aton-series, equipped with a 12W LED module. The light fixture has a ceramic base and a matt opal shade. Cairo Large LED is suitable for both indoor and outdoor use.

EAN / GTIN	7312907305328
E-number	7501362
Article no.	7305-800-12
Type designation	8262/LED



Specification

Material	Porcelain
Base colour	Grey (NCS S 6005-G50Y)
Glass	Matt opal glass
Glass thread (mm)	185,5 mm
Glass gasket	Silicone
Weight	3,66 kg
Diameter (mm)	340
Height (mm)	134
Lamp holder	LED
Light source	LED module, 12W **
Effect	12W
Lumen, light source	1350lm
Lumen, luminaires	1023
Colour temperature	3000K
MacAdam	3 SDCM
Life span	L80/B10: 47 000 h
Ra	Min 90
Rated voltage	230V
Dimmable	Back edge only - We recommend dimmers from ION, Schneider, Vadsbo and Niko
IP class	IP44
Insulation class	II
Energy class	E
D class	No
IK class	IK02
Ta	-30 - +25
Installation	Ceiling/wall
CC measurement (mm)	133, 70
Knock out opening	3
Cable inlet	Bottom inlet
Cable glands	Bottom inlet
Cable area, max	Max 3 x 2,5 mm ²
Bridging	Yes
Surface mounted cable	Yes
Connection	Terminal block
Family	Aton
Design	Håkan Svennesson SD

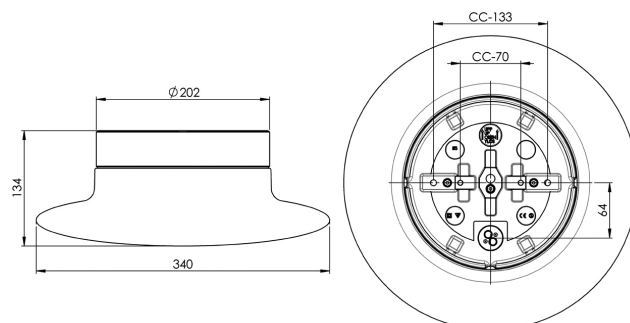

Maintenance

Disconnect the power to the luminaire. Unscrew the glass and clean it. Do not use detergents that contain solvents. Replace LED module if necessary. Check the gasket and replace it if necessary. Screw the shade back on.

Spare parts

Shade Cairo Large matt opal, Article no.: 1-6195-30
 Gasket silicone for thread 185,5 mm, Article no.: 03431
 LED module 12W 3000K IOT, Article no.: 1-54064-930

** Only use dimmers with manual trailing edge control. Do not use leading edge dimming or automatic setting as this can shorten the lifespan of the module.

If the luminaire is modified the person responsible for the modification shall be considered manufacturer. Subject to errors in text. We reserve the right to change the technical specifications (without notice).